

Eclipse BoostPak

Packaged Gas Booster Systems

Series MH

Version 2

Medium Flow Simplex with Heat Exchanger Option

Parameter	Specification						
Model Number	MH3314	MH3412	MH4414	MH4617	MH4619	MH4623	MH4628
Assembly Number	10024870	10024871	10024872	10024873	10024874	10024875	10024876
Booster	HB3314-1/2	HB3412-1/2	HB4414-1	HB4617-1	HB4619-2	HB4623-5	HB4628-5
Minimum Flow (cfh) ^a	50	150	150	150	150	300	150
Maximum Flow (cfh) ^a	5,300	11,600	20,400	23,000	17,800	33,000	14,600
Pressure Boost ^a	9	7	7	13	18	26	34
Turndown	106:1	77:1	136:1	150:1	120:1	110:1	100:1
Primary Voltage	b, c, d, e	b, c, d, e	c, d	c, d	c, d	c, d	c, d
Motor Horsepower	1/2	1/2	1	1	2	5	5
Approximate Wt. (lbs) ^f	870	900	1,000	1,200	1,300	1,520	1,670

Notes: a Ratings are nominal, in CFH of natural gas, at standard conditions and depend on customer interface piping.
b 115/230 VAC, 1Φ, 60hz
c 230/460 VAC, 3Φ, 60hz
d 208 VAC, 3Φ, 60hz
e 208 VAC, 1Φ, 60hz
f Weight is approximate
NEMA 4 rating; NEMA 7 rating option available (footprint increases with this option).

Dimensional Information in Millimeters (in)

BoostPak	Flange Sizes (150#)		Connection Data			
	Inlet	Outlet	A	B	C	D
MH3314	3	3	402 (15.8)	613 (24.1)	167 (6.6)	182 (7.2)
MH3412	4	3	364 (14.3)	552 (21.7)	224 (8.8)	185 (7.3)
MH4414	4	4	402 (15.8)	613 (24.1)	203 (8.0)	185 (7.3)
MH4617	6	4	435 (17.1)	684 (26.9)	307 (12.1)	192 (7.6)
MH4619	6	4	524 (20.6)	822 (32.4)	308 (12.1)	183 (7.2)
MH4623	6	4	549 (21.6)	895 (35.3)	322 (12.7)	185 (7.3)
MH4628	6	4	625 (24.6)	1054 (41.5)	316 (12.4)	190 (7.5)

BoostPak	Maximum Envelope					
	E	F	G	H	J	K
MH3314	737 (29)	1603 (63.1)	1943 (76.5)	1183 (46.6)	1083 (42.6)	1750 (68.9)
MH3412	762 (30)	1700 (66.9)	1906 (75.1)	1183 (46.6)	1158 (45.6)	1750 (68.9)
MH4414	762 (30)	1664 (65.5)	1934 (76.1)	1183 (46.6)	1133 (44.6)	1750 (68.9)
MH4617	762 (30)	1773 (69.8)	2025 (79.7)	1183 (46.6)	1233 (48.5)	1865 (73.4)
MH4619	711 (28)	1683 (66.3)	2080 (81.9)	1183 (46.6)	1233 (48.5)	1875 (73.8)
MH4623	889 (35)	2027 (79.8)	2206 (86.8)	1183 (46.6)	1233 (48.5)	2029 (79.9)
MH4628	965 (38)	2162 (85.1)	2362 (93.0)	1277 (50.3)	1253 (49.3)	2180 (85.8)

Notes: Dimensions shown are nominal. Variations of 2% may occur due to thread engagement and assembly tolerances.

Dimensions in Millimeters (inches)
Medium Flow Simplex with Heat Exchanger Option

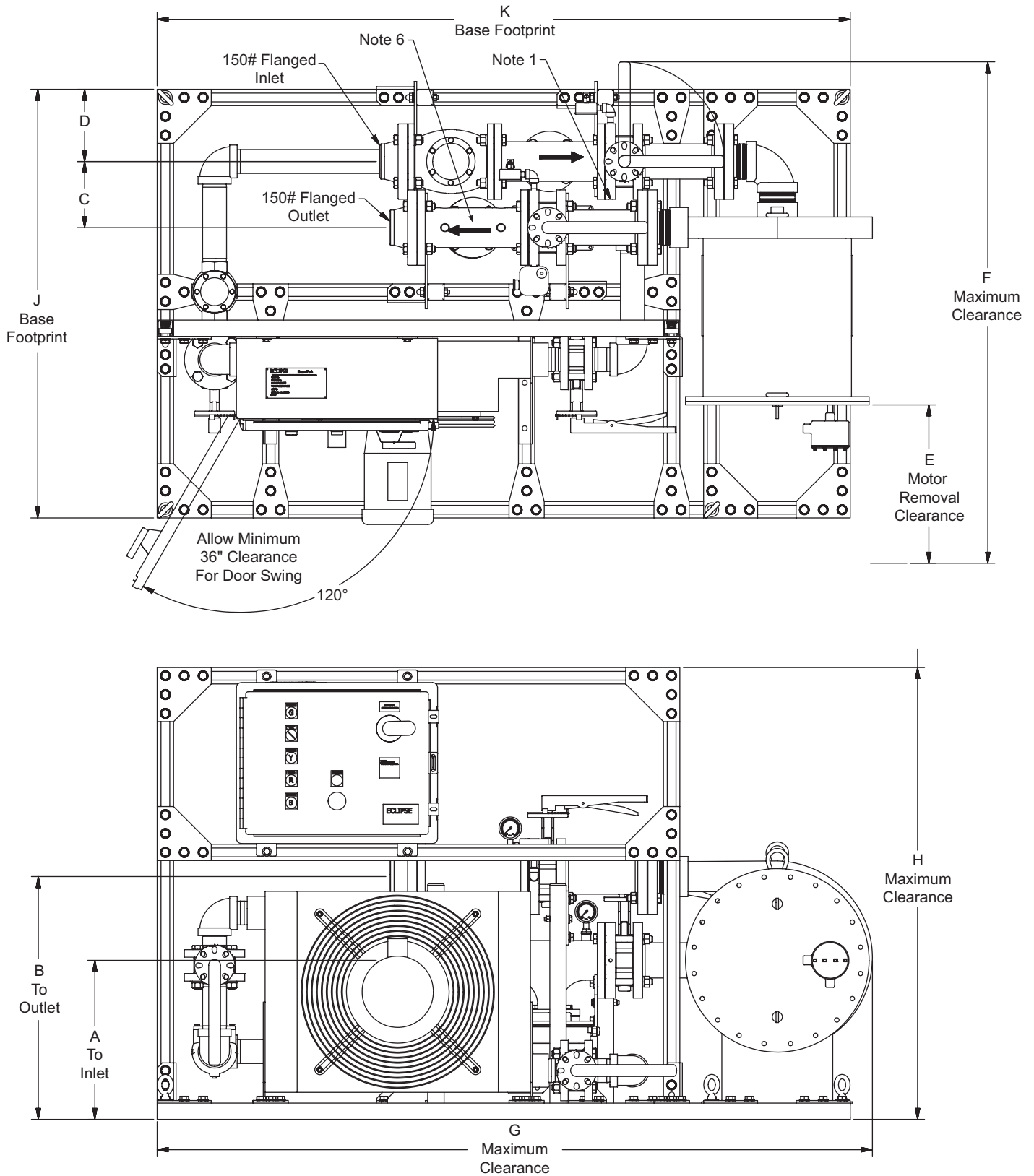

- Note 1* Pressure Switch Kit location when factory mounted.
Note 2 When Pressure Switch Kit is supplied loose by Eclipse, it is to be installed by customer in accordance with local codes.
Note 3 Customer is to secure Boostpak to foundation through unistrut base (customer drilled holes).
Note 4 Dimensions shown are nominal. Variations of 2% may occur due to thread engagement and assembly tolerances.
Note 5 Ensure proper clearances for motor removal.
Note 6 Flow control switch kit location, when factory mounted.





Offered By:

Power Equipment Company
2011 Williamsburg Road
Richmond, Virginia 23231
Phone (804) 236-3800
Fax (804) 236-3882

www.peconet.com